

CERN/PS/AE/77-15

10.3.1977

A MODULATED FAST BUMP FOR THE CPS CONTINUOUS TRANSFER

by

D. Fiander, D. Grier, K.D. Metzmacher, P. Pearce

Paper presented at 1977 Accelerator Conference, Chicago

D.C. Fiander, D. Grier, K.D. Metzmacher, P. Pearce  
PS Division, CERN, Geneva, Switzerland.

Summary

The CERN SPS receives beam from the CPS by the continuous transfer process. The paper outlines the role of a modulated fast bump in this process and describes the magnets and pulse generators which produce it. Particular attention is given to the high voltage staircase pulse generator which determines the degree of modulation of the bump. Operating experience since the start of SPS commissioning is reported.

Introduction

The 28 GeV CPS is the injector for the 400 GeV SPS. The beam is transferred by the Continuous Transfer (CT) process at 10 GeV/c. In this process the CPS beam is progressively pushed across an electrostatic septum by a modulated fast bump, so as to shave a constant stream of protons over a number of CPS turns. Preliminary results of this fast shaving extraction were reported in the 1973 conference<sup>1</sup>; a final system was constructed in 1975 and has been in constant use since April 1976 when PS commissioning started.

A description is given of the hardware required for generating the modulated fast bump which steers the CPS beam across the electrostatic septum. The modulation determines the turn to turn intensity of the extracted beam and the number of turns over which extraction takes place.

Lay-Out of CT Elements

The schematic lay-out of the CT elements is shown in Fig. 1. The fast bump is initiated by FB 21. This steers the beam over the electrostatic septum ES 31, which is located between quadrupoles Q25 and Q5. The quadrupoles serve to blow up the beam transversely and reduce the momentum compaction factor at the ES. The fast bump is then cancelled by FB9. That part of the beam which has entered the ES 31 is extracted by the magnetic septum magnet SM 16. The beam which has not been extracted by SM 16 re-enters FB 21.

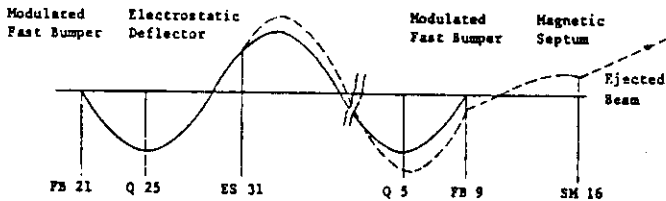

Fig. 1. Simplified Schematic Lay-out of CT Elements

The kick strength of the fast bump can be adjusted for each machine turn such that a constant intensity of extracted beam is maintained over the desired number of CPS turns, normally ten.

Characteristics and Design of Fast Bumper System

General Description

The fast bumper system comprises identical magnets in straight sections 21 and 9 and the pulse generators for their excitation (Fig. 2). Limitation of available CPS straight section length imposes certain constraints on the system design. A compromise has to be found between acceptable kick-strength, rise-time and reasonable pulse generator voltages. The solution adopted is the use of separate pedestal and staircase dipole magnets (named after the form of their excitation pulses). The two dipoles are pulsed synchronously to yield a total

kick of up to 1.26 mrad at 12 GeV/c.

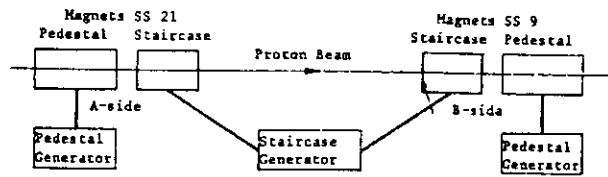

Fig. 2. Fast Bumper System Block Diagram

The single turn pedestal magnet is excited by a flat topped pulse covering at least eleven CPS turns. To obtain sufficient kick from the staircase magnet a two turn short-circuited design is used. The longer rise-time inherent in this design is partly offset by a shunt capacitor. The excitation pulse of the staircase magnet is created from eleven sequential steps, each lasting one CPS turn (2.1  $\mu$ s) and of amplitude which can be adjusted independently.

Magnets

Both pedestal and staircase magnets are window frame ferrite magnets and are installed in a common vacuum tank. Their design is conventional except for the breaking of the ferrite circuit on the vertical median plane by the insertion of a wedge shaped conductor; this lowers the coupling impedance seen by the beam. Magnet parameters are contained in Table I and Fig. 3 shows the staircase magnet with the vacuum tank cover removed.

TABLE I. Magnet Parameters

		Pedestal	Staircase
Horizontal aperture	(mm)	160	160
Vertical aperture	(mm)	53	53
Useful horizontal aperture (> 98% kick)	(mm)	$\pm 75$	$\pm 75$
Physical length	(cm)	500	390
Maximum kick-strength at 12 GeV/c	(mrad)	.55	.71
Corresponding ferrite flux density	(gauss)	1960	1750
Ferrite type		8C11	8C11
Remanent $\int \delta dl$	(gauss-cm)	.9	.8
Inductance	( $\mu$ H)	2.3	7.0
Shunt capacitance	(nF)	-	4.7
Field rise-time (0 to 90%) level	(ns)	490	600
Terminating resistance	(ohms)	8.3	(step 1) 0

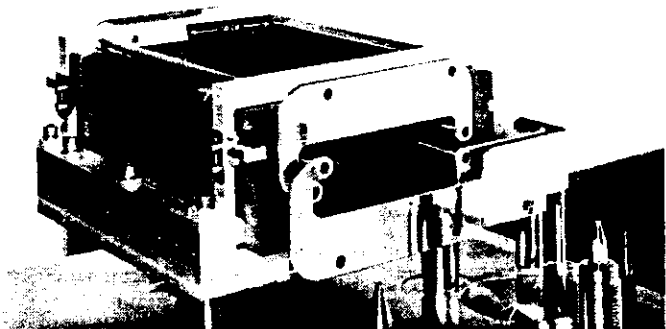

Fig. 3. Staircase Magnet with Tank Cover Removed

Pedestal Generator

Each pedestal magnet is excited from a dedicated lumped element pulse forming network (PFN). This uses a LCR head cell to improve rise-time but is otherwise of conventional design. Switching is by EEV CX1159A thyatron mounted in a low inductance coaxial housing in the same oil tank as the PFN and its pulsed resonant charging supply. The PFN impedance of 7.6 ohm is deliberately lower than the magnet termination of 8.3 ohm to

prevent reverse current in the thyatron at the end of the pulse. Some of the pedestal pulse generator parameters are found in Table 2.

TABLE 2. Pedestal Pulse Generator Parameters

PFN impedance	(ohms)	7.6
Pulse duration	( $\mu$ s)	> 23.5
No. of cells		20 + head cell
Total capacitance	( $\mu$ F)	1.76
Maximum charging voltage	(kV)	32
Corresponding pulse current	(amp)	2000
Current rise-time in matched load (10-90%)	(ns)	45
Flat top ripple	%	$\pm .8$
Recharging time	(ms)	6
Max. repetition rate	(pulses/s)	1
Shot to shot stability		< $10^{-3}$

#### Staircase Generator

The staircase magnets of both straight sections are excited from a single staircase pulse generator; the schematic diagram is shown in Fig. 4.

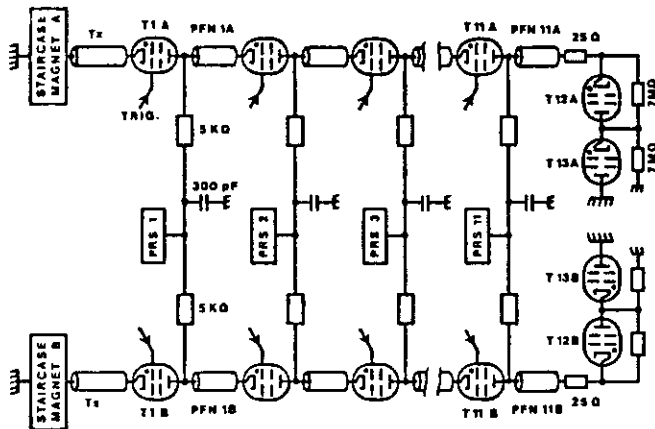

Fig. 4. Schematic of Staircase Pulse Generator

This pulse generator is the key element in the fast bumper system. It consists essentially of two groups of eleven series connected step pulse generators, each group feeding one of the staircase magnets. Each step pulse generator comprises a 25 ohm cable PFN formed from two RG 220/U cables and a CX1159A thyatron switch. A pulsed resonant charging power supply charges both PFN's associated with the same step in the two groups. This series arrangement of step pulse generators has the virtue of ease of control of individual step amplitude. The penalty can be a reliability problem due to the interdependence of all step generators; experience shows that this can be overcome by comprehensive diagnostics and careful design. The thyatrons for the same steps of each group, together with the high voltage components of the resonant charging power supply, are housed in a single mobile oil filled tank. For easy replacement in the case of a failure all tanks and PFN's are fitted with high voltage plugs and sockets.

The functioning of the staircase pulse generator can be described as follows. All PFN's are charged synchronously by the eleven pulsed resonant supplies PRS1-11. The charging time is short and independent of the desired amplitude; this is advantageous for the thyatrons as it minimises the differential thyatron voltage and lessens the risk of spontaneous breakdowns. The PFN's are discharged by sequential triggering of the thyatrons T1-T11 into the transmission cables leading to a magnet. A forward wave pattern of eleven steps is created, corresponding in form to the desired staircase excitation of the magnet. Each step has a length of 2.1  $\mu$ s (the proton flight time around the CPS) and

is determined by the differential thyatron triggering. D-12 The PFN's are about 5% longer than necessary for the generation of this 2.1  $\mu$ s pulse, so rendering thyatron conduction more certain.

In addition to creating a forward wave pattern the sequential triggering of T1 - T11 generates a steep backwards travelling wave pattern in the PFN's, the form being largely determined by the overlength of the PFN's. The forward wave pattern which excites the magnet is fully reflected at its short circuited termination, thus doubling the magnet current. This reflection gives rise to another backwards travelling wave pattern in the PFN's, separated from the first by 2.1  $\mu$ s, the chosen two way travelling time of the transmission cables. These two wave patterns propagate backwards through the already conducting thyatrons of the step generators. When the first wave pattern reaches the end of PFN 11 it is fully reflected at the open circuit presented by thyatrons T12 and T13 connected as an inverse diode. This reflection returns to the magnet and de-energises it. The second backwards going wave pattern self-triggers T12 and T13 and is absorbed in a 25 ohm terminator. In Fig. 5 the currents in the magnet, the fifth step thyatron and in the terminator are shown for a typical ejection.



a) magnet current  
vert. 250 A/div  
hor. 5  $\mu$ s/div

b) current in  
fifth step  
thyatron

c) current in  
25 ohm  
terminator

Fig. 5. Typical Staircase Currents

The above description covers the case of a staircase composed of positive steps. Unfortunately, because of coherent beam oscillations, it is sometimes necessary to employ negative steps. In this case there is some small loss of quality of these negative steps because of the inability to trigger the associated thyatrons. This results in slightly incorrect step length due to PFN over-length and sometimes an unwanted drop in current lasting for the thyatron anode delay time.

The choice of PFN cable for the staircase generator is most important. The cable must have good high voltage hold-off, low attenuation and reasonable cost - properties difficult to reconcile. RG 220/U is used because it is a commercial design and has an impedance level which at the same time minimises attenuation and optimises hold-off voltage; the core is a special void free single layer extrusion. Two RG 220/U cables in parallel give an acceptable impedance for the generator and allow lower inductance connections to the coaxially mounted thyatrons than would be possible with a single cable PFN. Cable attenuation increases the step rise-time; the increase is proportional to the square of the length through which the step propagates before reaching the

magnet. Cable attenuation also reduces the step amplitude; the percentage reduction depends on the form of the generated pulse but is typically about 8% for step 11. Thyatron losses further reduce the amplitude so that in practice the step 11 PFN voltage must be raised by about 11% above that needed in a loss-less system.

Some parameters and operating conditions of the staircase pulse generator are listed in Table 3 and a view of part of the generator is shown in Fig. 6.

TABLE 3. Staircase Pulse Generator Parameters

System impedance	(ohms)	25
No. of steps		11
Step length	( $\mu$ s)	2.1
Min./Max. step 1 PFN voltage	(kV)	6/25
Max. step 11 PFN voltage	(kV)	42
Max. step to step PFN voltage	(kV)	+ 20/-10
Step 1 rise-time (10-90)% into short-circuit	(ns)	< 50
Step 11 rise-time (10-90)% into short-circuit	(ns)	550
PFN recharging time	(ms)	3.5
Max. repetition rate	(pulses/s)	1
Shot to shot stability		< $10^{-3}$

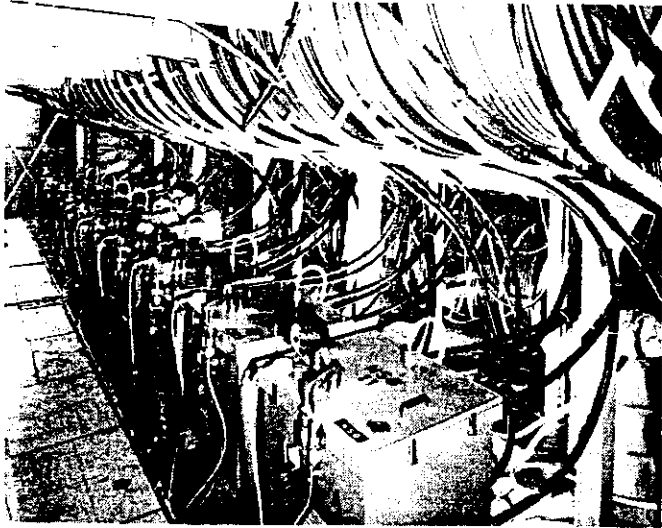

Fig. 6. View of Generator

#### Protection, Monitoring and Controls

Because of the high equipment cost and the risk of consequential damage, the fast bumper system is fitted with a variety of protection devices. These range from conventional vacuum and temperature gauges to sophisticated electronics to locate spontaneous breakdowns of thyratrons and excessive reverse voltages. Current waveforms at strategic points of the staircase generator are also compared for current balance. The system is further protected by controls software which guards against false operation.

Monitoring facilities are provided for power supply and fast pulse signals. The analogue waveforms are displayed on storage scopes via multiplexers which automatically select the appropriate trigger. Delay facilities synchronised with the CPS revolution frequency allow easy study of individual staircase steps. The fast bumper system is controlled along with other equipment of the CT process by a PDP 11/40 computer via CAMAC. All control functions, including PFN voltage adjustment and timing, can be made from the Main Control Room console. Operating data and fault messages are displayed on TV screens. The control system is being extended to include automatic optimisation of the form of the ejected beam by adjustment of the fast

bumper voltages - early trials are most encouraging.

D-12

#### Operating Experience

The equipment has operated for more than 3000 hours and has proven to be very reliable in spite of the large number of series elements in the system. The modular construction of the high voltage equipment has resulted in short repair times. The number of equipment failures is small, the total down time being < 0.25%.

The SPS is normally filled by a single transfer of the CPS beam extracted over ten turns. Typical operating voltages for an extraction of  $7 \times 10^{12}$  protons per pulse are 18 kV on the pedestal generator and 10 kV and 30 kV respectively for steps 1 and 10 of the staircase generator; the corresponding first and tenth turn kick strengths are .67 and 1.1 mrad at 10 GeV/c. A typical ejected ten turn beam current measured in the SPS transfer line is shown in Fig. 7. For high intensity tests two consecutive transfers of beam fully extracted over five CPS turns have been satisfactorily made.

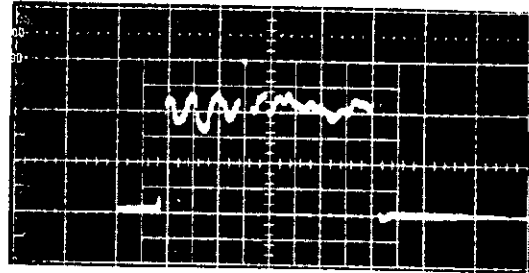

Fig. 7. Typical Ejected Beam Current 5  $\mu$ s/div.

The conclusion drawn from operation to date is that the fast bumper system can meet reliably the requirements for ten or five turn extractions. There is a comfortable margin of deflecting power at 10 GeV/c. The stability and ease of control ensure a consistent quality of the transferred beam.

#### Acknowledgements

The authors wish to acknowledge the support of D. Bloess and the assistance of many of their colleagues in the PS Division in the realisation of this equipment in particular that of A. Krusche (Parameter Specification), H. Riege (CT computer system) and J. Boucheron (General Timing Equipment).

#### References

1. The Fast Shaving Ejection for Beam Transfer from the CPS to the CERN 300 GeV Machine. C. Bovet, D. Fiander L. Henny, A. Krusche, G. Plass. 1973 Particle Accelerator Conference, San Francisco.